

# MC60 Electric Cream Separator

## Use & Care Instructions



Read this manual carefully before using your Cream Separator. Please note: The top reservoir where the milk goes is called the "Milk tank." The spinning assembly which actually separates the cream is called the "Bowl" assembly. This terminology is used throughout this manual

### UNPACKING & INSPECTION

Remove the machine and all spare parts from the packing case and check that all parts are present and in good condition. Besides the unit itself you should have spares and tools as listed below:

### SET-UP

Fasten the machine to a suitable table with appropriate hardware (not included). Use a leveling device to make sure the machine is perfectly level. This is very important for the long life and smooth running of the machine.

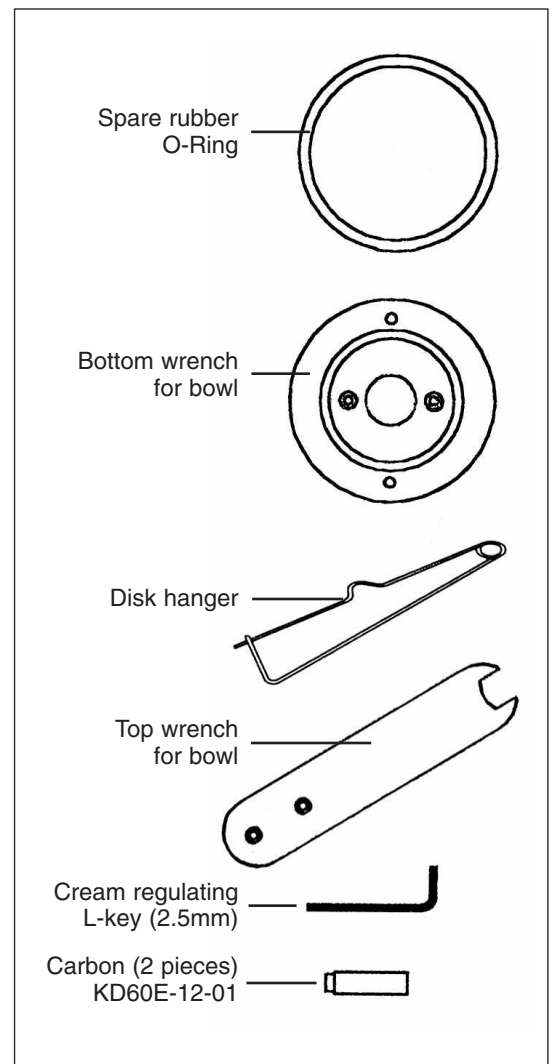

## CLEANING OF MILK CONTACT PARTS

The bottom wrench should be bolted to your work table for ease of disassembly of the bowl. Dismantle as shown in Figure E and Figure F and wash all parts in soap and warm water until thoroughly clean. Rinse well and wipe dry. All the other milk contact parts shown in Figure D except the body, should be washed the same way in soap and warm water including the milk tank, float, spouts, etc. Rinse well and wipe dry. This dismantling and washing procedure must be followed before first use and after every use.

## ASSEMBLY

Put the bowl assembly back together according to Figure F. Make sure the bowl cover pin fits into the bowl base notch. Tighten the bowl nut well. Place the milk contact parts over the spindle according to Figure D starting with the milk spout. Next place the bowl assembly making sure it seats properly on the tapered head of the spindle shaft. Put the cream spout on next. Place the float chamber, the float and the milk tank in place as shown. Make sure the milk tank is placed with the "ON" label at the front. Tighten the tank tap handle. Put the tap in "OFF" position. Your separator is now ready for use.

## MILK PREPARATION AND SEPARATION

Milk must be strained to remove any dirt or particles. Milk must not be cold, homogenized or sour. For best results, separate milk right out of the cow. If that is not possible, rewarm the milk to approximate cow body temperature 100°F (38°C). It is very important that the milk is warm and stays warm throughout the separating process. Pre-warm the separator as follows: Heat approximately 8 quarts (7 liters) of hot water to 150°F (66°C). Pour about 4 quarts of hot water

into the tank. Place containers under the spouts to catch the water. Open the tap and turn the machine on so the hot water flows through the separator and warms all the milk contact parts. Close the tap. Now pour 6 quarts (6 liters) of warm milk in the tank. Make sure you have in place adequately-sized containers to receive the cream and skimmed milk which will come out of the spouts.

Turn the machine on and allow about 1 full minute to let the machine get up to the proper speed. Turn the tap to the "ON" position. Observe the process until all of the milk has passed out of the milk tank. Let the cream and milk drip for another moment, then remove the containers. Put another container in place to catch the rinse water then immediately pour about 4 quarts (3 liters) of hot water (150°F) into the milk tank. This will clean the last cream from the disks. When the water has run out of the milk tank, turn off the machine and allow the machine to come to a complete stop.

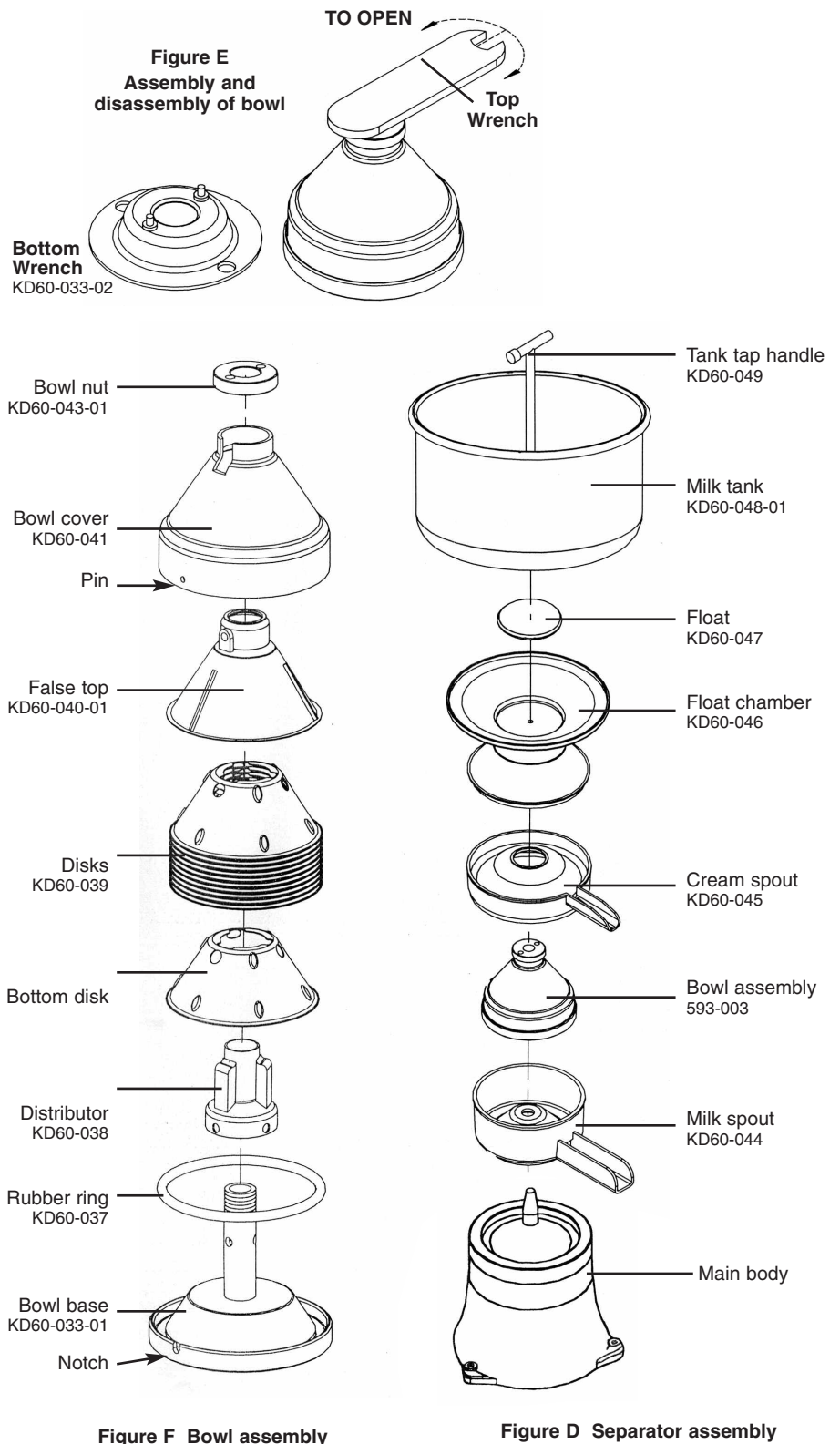

## CLEANING AND STORAGE

After separating your batch of milk, dismantle the spinning bowl and clean all milk contact parts thoroughly as described above. Dry thoroughly and store in a clean dry place.

## REGULAR MAINTENANCE

Proper storage and cleaning is the only regular maintenance required. Inspect and replace any parts that become worn or damaged.

## TROUBLESHOOTING

**PROBLEM:** The separator vibrates.

1. Check to make sure your separator is perfectly level.
2. Check to make sure the bowl is in good order, nothing is damaged or misaligned, it is assembled correctly and the nut is well attached.

**PROBLEM:** Milk does not separate correctly.

1. The most common cause is cold milk or a cold machine. Make sure the milk is not sour, homogenized or too cold. Follow the instructions for pre-warming the separator.
2. Make sure the cream regulating screw is not damaged or loose. The screw is found at the top of the bowl as shown below.

**NOTE:** The cream regulating screw is adjustable but should only be used as a last resort after all other problems have been checked. The screw has been pre-set at the factory for correct functioning. If you feel the cream is still too thick or too thin, adjust the screw with the L-key as shown at right. Turn only a quarter of a turn at a time as the setting is very sensitive. Test the new setting on a batch of milk before adjusting further. Be sure you are following all instructions, inspections and cleaning as described in this manual.

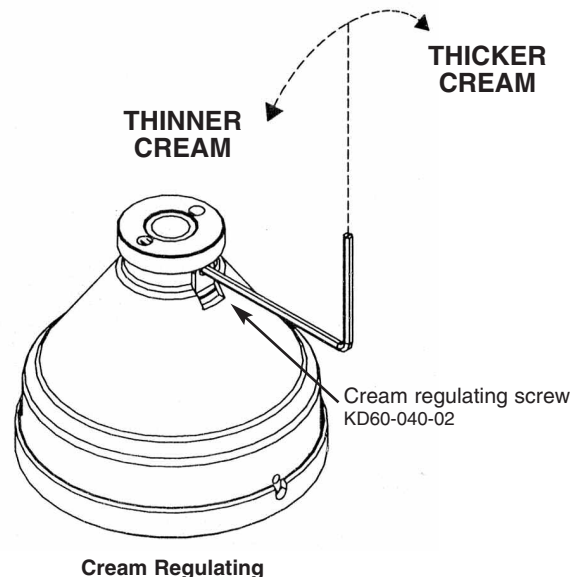

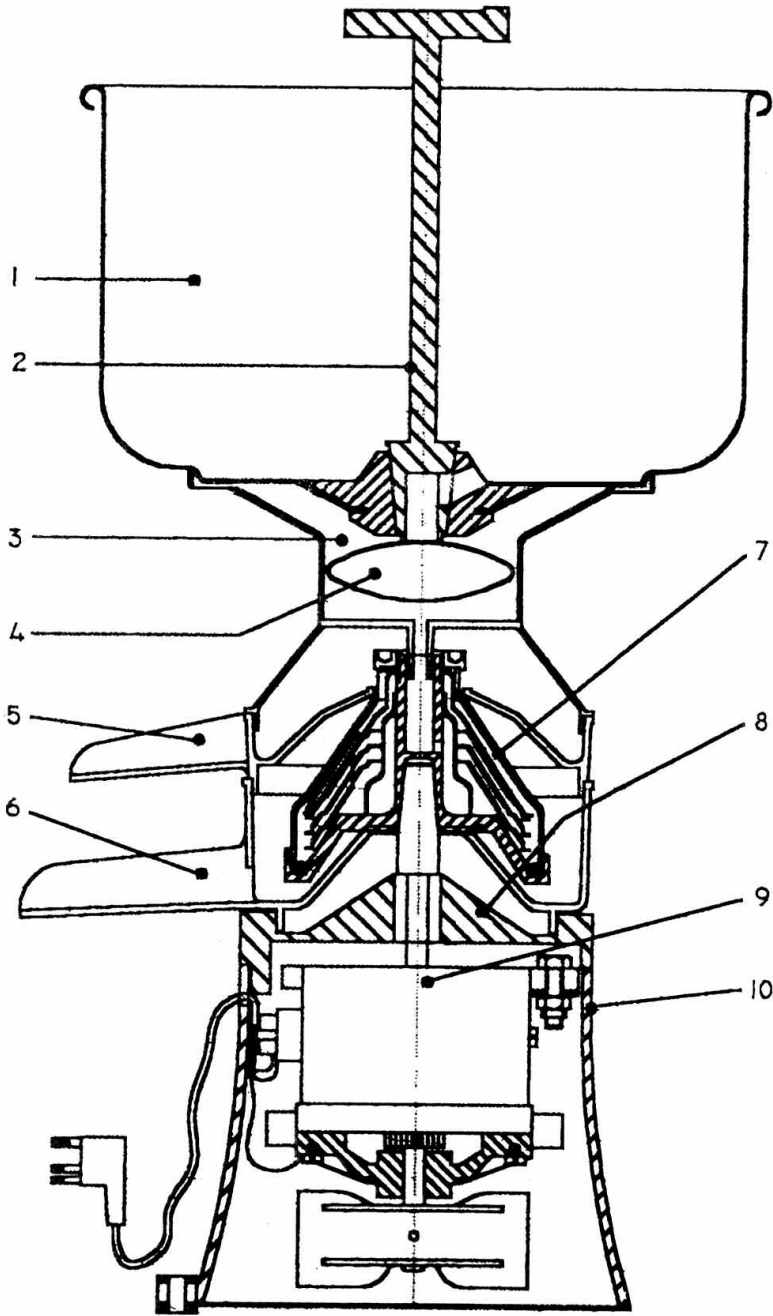

- |   |                          |    |                             |
|---|--------------------------|----|-----------------------------|
| 1 | Milk tank KD60-048-01    | 6  | Skimmed milk spout KD60-044 |
| 2 | Tank tap handle KD60-049 | 7  | Bowl assembly 593-003       |
| 3 | Float chamber KD60-046   | 8  | Main body top               |
| 4 | Float KD60-047           | 9  | Motor KD60E-12              |
| 5 | Cream spout KD60-045     | 10 | Main body bottom            |

**The *Coburn* Company, Inc.**

P.O. Box 147  
Whitewater, Wisconsin 53190

Toll-Free  
**1-800-776-7042**

Phone: 262-473-2822  
Fax: 262-473-3522